

Is ACCTRAN better than DELTRAN?

Ingi Agnarsson^{a,b*} and Jeremy A. Miller^c

^a*Institute of Biology, Scientific Research Centre of the Slovenian Academy of Sciences and Arts, Novi trg 2, PO Box 306, SI-1001 Ljubljana, Slovenia;*
^b*Department of Biology, University of Akron, Akron, OH 44325-3908, USA;* ^c*Department of Entomology, California Academy of Sciences, 875 Howard Street, San Francisco, CA 94103, USA*

Accepted 15 May 2008

Abstract

When parsimony ancestral character reconstruction is ambiguous, it is often resolved in favour of the more complex character state. Hence, secondary loss (secondary “absence”) of a complex feature is favoured over parallel gains of that feature as this preserves the stronger hypothesis of homology. We believe that such asymmetry in character state complexity is important information for understanding character evolution in general. However, we here point out an inappropriate link that is commonly made between this approach and the accelerated transformation (ACCTRAN) algorithm. In ACCTRAN, changes are assigned along branches of a phylogenetic tree as close to the root as possible. This has been taken to imply that ACCTRAN will minimize hypotheses of parallel origins of complex traits and thus that ACCTRAN is philosophically better justified than the alternatives, such as delayed transformation (DELTRAN), where changes are assigned along branches as close to the tips as possible. We provide simple examples to show that such views are mistaken and that neither ACCTRAN nor DELTRAN consistently minimize parallel gain of complex traits. We therefore do not see theoretical grounds for favouring the popular ACCTRAN algorithm.

© The Willi Hennig Society 2008.

Character optimization is the process by which alternative reconstructions of a character on a cladogram are evaluated. Under parsimony, when alternative reconstructions are equally costly, character optimization is ambiguous (Farris, 1970). The popular algorithms for resolving ambiguous character optimization are accelerated transformation (ACCTRAN), where changes are assigned along branches of a phylogenetic tree as close to the root as possible (passing up), and delayed transformation (DELTRAN), where changes are assigned along branches as close to the tips as possible (Farris, 1970; Swofford and Maddison, 1987). As originally proposed (Farris, 1970) and developed (Swofford and Maddison, 1987, 1992), ACCTRAN and DELTRAN were not presented as one being in some general way superior to the other. Today, however, ACCTRAN is much more widely used than DELTRAN. For example, Google

Scholar finds 1730 references to ACCTRAN but approximately 720 to DELTRAN (897 hits, minus about 20% that refer to a computer language) and almost all papers that mention DELTRAN also use ACCTRAN, sometimes preferentially.

This note points out that we believe current preference for ACCTRAN stems from a mistaken link made by De Pinna (1991) between a philosophical justification for preferring reversals over parallelism and ACCTRAN. De Pinna’s philosophical argument based on asymmetry in character state complexity (see below) has received considerable acceptance and we certainly see merit in it. However, neither it nor any other argument we have seen offers theoretical grounds for preferring ACCTRAN over DELTRAN in general. Rather, we argue that each case must be evaluated independently with respect to the complexity of character states (see below). We start by briefly reviewing some of the basic properties of ACCTRAN and DELTRAN.

*Corresponding author:

E-mail address: iagnarsson@gmail.com

Some properties of ACCTRAN and DELTRAN

ACCTRAN and DELTRAN represent just two among many alternative most parsimonious reconstructions (MPRs) on any given tree (Miyakawa and Narushima, 2004). They represent extremes of the distribution of MPRs in “MPR-space” (all MPRs for a given tree, see Minaka, 1993); for example, ACCTRAN is the MPR that minimizes the lengths of all subtrees of a given tree (Minaka, 1993)—the so-called “First Theorem on ACCTRAN” (Miyakawa and Narushima, 2004). As stated by Miyakawa and Narushima (2004, p. 171) “... ACCTRAN on a rooted el-tree [any given tree] is the unique MPR on the tree for which the lengths of all subtrees are minimized, that is, the subtree-complete maximum-parsimony of ACCTRANs” (see also Narushima and Misheva, 2002). Based on this property, Minaka (1993) proposed the “distortion index” calculated as the cumulative difference between the lengths of all subtrees of a given MPR compared with that of ACCTRAN. Minaka (1993) found that DELTRAN was the MPR that maximizes the distortion index. Of course, all MPRs are, by definition, equal in terms of the length of the total tree. However, ACCTRAN monotonically spreads change so as to minimize the length of all subtrees while DELTRAN maximally distorts monotonicity by distributing change unevenly among subtrees—as stated by Minaka (1993, p. 292) “... this means that in DELTRAN optimization, the total amounts of character state changes are more unevenly scattered over the full tree than in ACCTRAN.” This property is important as ACCTRAN, by evenly spreading change, may better fit assumptions of rate constancy incorporated in many popular models used for phylogenetic reconstructions, especially of molecular data. On the other hand, DELTRAN may be more appropriate in cases where rate constancy is unlikely, as may be the case with morphological characters showing character state asymmetries.

ACCTRAN and DELTRAN represent opposite MPR extremes, respectively maximizing ambiguous character state change as close to the root, or the tips, as possible. This means that ACCTRAN will, on average, lead to greater estimated branch lengths between internal nodes than DELTRAN, while DELTRAN will, on average, lead to greater estimated terminal branch lengths than ACCTRAN. This property is important if those branch lengths are subsequently used as information, e.g. to date the splitting of lineages using a molecular clock or other methods. It is also important as ACCTRAN and DELTRAN may represent reasonable upper and lower bound estimates of internal and terminal branch lengths and hence provide a good framework for sensitivity analyses. For example, Forest et al. (2005)

used both to date phylogenetic trees and, unsurprisingly, found that ACCTRAN tended to give older age estimates for nodes. Although ACCTRAN and DELTRAN have been by far the best studied, many alternative options may be possible for a given character on a tree (Maddison and Maddison, 2002). For example, one might choose the MPR that maximizes similarity of reconstructed internal nodes to a given terminal (species) in the tree, or choose the MPR that maximally reconstructs a given character state (e.g. “1”) on terminal branches. For morphological studies, in particular, or studies using molecular phylogenies to trace morphological/behavioural traits, one MPR property that is often sought is one that maximizes parallel loss over convergent gains of complex traits (De Pinna, 1991). In spite of frequent claims to the contrary, this last condition is not satisfied by ACCTRAN (see below).

Asymmetry in character state complexity

De Pinna (1991, p. 386) argued that “... absences stand at a lower ontological level as observations, when compared to presences (Nelson and Platnick, 1981: 29; Patterson, 1982: 30).” In other words, there can be asymmetry in the information content of primary homology statements of character states. Complex features share detailed similarities strengthening the conjecture of homology between them, whereas absences are a weaker form of primary homology statements (see also Rieppel and Kearney, 2002). Therefore, a theoretical basis may exist for favouring some equally parsimonious optimizations over others. In the absence of compelling evidence to the contrary, ambiguous optimization is better resolved in favour of secondary losses (reversals) over parallel gains of complex structures. This is more consistent with the stronger conjecture of homology based on observable detailed similarity, rather than mere absence (De Pinna, 1991); complexity tests similarity (Agnarsson and Coddington, 2008; see also Richter, 2005; Scholtz, 2005; Agnarsson et al., 2007). When characters lack asymmetry in character state complexity (e.g. the states “red” and “blue”), little, if any, grounds exist to favour one optimization over another (Richter, 2005).

However, we believe that De Pinna (1991) erred when he concluded that ACCTRAN is a superior algorithm for preserving strong homology statements (see Examples, below). He claimed (De Pinna, 1991, p. 388) that ACCTRAN favours reversals over parallelism and that therefore “... ACCTRAN optimization better conforms with the notion that the conjecture of primary homology should be held valid unless demonstrated false by parsimony considerations. It thus can be considered as a theoretically superior algorithm for tracing character

Table 1

Selected quotes from a range of recent literature that link ACCTRAN optimization with preserving stronger conjecture of homology (e.g. presence over absence). We note here that the phrase “Farris optimization” is typically used to refer to additive (ordered) character states (e.g. Schuh, 2000), not to ACCTRAN optimization (contra Benjamin, 2004; Hormiga, 2003)

Justification	Reference
“I used the ACCTRAN option (Farris optimization), which favours secondary loss over convergence to explain homoplasy and therefore maximizes homology (Hormiga, 1994; Griswold et al., 1998; Schuh, 2000), although not of losses or reductions. It also minimizes homology of presence of a primitively present character.”	(Benjamin, 2004: 8)
“Ambiguous characters were ACCTRAN optimized (Swofford and Maddison, 1987), where reversals are chosen over convergences, thus maximally preserving hypothesis of homology (De Pinna, 1991).”	(Britto, 2003: 122)
“Given that different optimizations did not affect the number and nature of shared convergences, we present here the results from ACCTRAN optimization.”	(Gaubert et al., 2005: 870)
“ACCTRAN assumes that reversals are more likely than convergence, whereas DELTRAN optimization assumes convergences are more likely than reversals.”	(Gregorin and Ditchfield, 2005: 404)
“I present the character support for nodes of my resulting two trees under accelerated transformation (ACCTRAN) optimization (as opposed to delayed transformation, or DELTRAN). I favor this optimization because it favours loss of complex structures, rather than independent gains (Kitching et al., 1998)...”	(Hilton, 2003)
“Ambiguous character optimizations were usually resolved so as to favor reversal or secondary loss over convergence (Farris optimization or ACCTRAN)...”	(Hormiga, 2003: 263)
“... by favouring the acquisition of a character, with subsequent homoplasy accounted for by reversal... accelerated transformation maintains our original conjecture of the character as a putative synapomorphy. In contrast by treating homoplastic characters as independent derivations, delayed transformation rejects our original hypothesis of primary homology. For this reason De Pinna (1991) asserted that accelerated transformation optimization is the theoretically superior algorithm for tracing character evolution.”	(Kitching et al., 1998: 73)
“To trace character evolution, these traits were optimised onto the most parsimonious trees using the delayed transformation (DELTRAN) optimization method (Swofford and Maddison, 1987), favoring convergences over reversals.	(Martel et al., 2004: 141)
“... ACCTRAN resolution (which accelerates changes towards the tree’s root; i.e. changes among states happen earlier on the tree, thus increasing the number of reversals), and after applying a DELTRAN resolution (which delays changes away from the root; i.e. state changes occur later on the tree, thus increasing independent gains) (Swofford and Maddison, 1987).”	(Mooring et al., 2004: 22)
“Ambiguous optimisations were resolved using accelerated transformation (ACCTRAN) or Farris optimisation, which favours reversals over parallelisms to explain homoplasy (Farris, 1970; Swofford and Maddison, 1987, 1992; Maddison and Maddison 1992) and therefore maximizes homology (Griswold et al. 1998).”	(Prendini et al., 2005: 208)
“The hypothesis containing a homology hypothesis should be preferred over the one which does not in cases of present/absent scoring, and also where both hypotheses are equally parsimonious, because the hypothesis containing the homology hypothesis is the more severely tested (i.e. it has been tested in two independent tests). This is common practice and known as ACCTRAN optimization.”	(Richter, 2005: 116)
“Thus, ACCTRAN and DELTRAN algorithms were applied to each character tree, resulting in a total of six ancestor state reconstructions. The ACCTRAN algorithm accelerates changes in traits toward the root of the tree, maximizing early gains and forcing early subsequent reversals. The DELTRAN algorithm, on the other hand, delays changes in traits away from the root, thus maximizing parallel changes (Maddison and Maddison, 2001).	(Shelley and Blumstein, 2005: 171)
“Character state distribution was examined using ACCTRAN optimization following De Pinna (1991: 367) under which ambiguous character distributions are resolved under the optimization that maximizes reversals rather than parallelisms within the resultant phylogenetic tree.”	(Zanata and Vari, 2005: 3)
“... the ACCTRAN reconstruction which originated with Farris [2], which is phylogenetically considered a more meaningful one of the many possible MPRs. The name “ACCTRAN” results from “accelerated transformation”, which means that character state changes are accelerated as far as possible with respect to the specific root; this property is selected in reversals of earlier changes in the same lineage than in parallel changes in different lineages...”	(Miyakawa and Narushima, 2004: 171)

Table 1
(Continued)

Justification	Reference
“DELTRAN...means that character state changes are postponed as long as possible with respect to the specific root. Biological implications are that DELTRAN minimizes reversal and maximizes convergence whereas ACCTRAN maximizes reversal and minimizes convergence...”	(Miyakawa and Narushima, 2004: 186)

evolution when compared to the DELTRAN procedure.”

It is clear when browsing current literature that use of ACCTRAN dominates (see above). To show the broad use of ACCTRAN we here take some examples from recent literature on a range of taxa, media and philosophical approaches (Table 1). We do not intend to single out these authors for criticism. On the contrary, we feel that explicit justification of methods used such as those that appear in Table 1 is preferable to the lack of it because it facilitates discussion and debate that can move science forward (cf. Wiens, 2001). Similarly, we do not mean to imply that acceptance of De Pinna’s argument is universal. Many authors use both ACCTRAN and DELTRAN and/or other MPRs, and choose the method appropriate in each case, do both and compare the results, etc. Nevertheless, we feel justified in focusing on the “De Pinna view” because it has played a role in the current dominance of ACCTRAN. It should be noted that our main point does not rest on the validity of philosophical arguments such as De Pinna’s to prefer one optimization over another. Researchers may disagree over circumstances that justify favouring reversals over parallelisms. Regardless, we observe that use of ACCTRAN dominates and we must ask whether this is justifiable.

Arguments in the literature often closely follow that of De Pinna (1991): “Ambiguous characters were ACCTRAN optimized (Swofford and Maddison, 1987), where reversals are chosen over convergences, thus maximally preserving hypothesis of homology (De Pinna, 1991).” (Britto, 2003, p. 122); and “ACCTRAN assumes that reversals are more likely than convergence, whereas DELTRAN optimization assumes convergences are more likely than reversals.” (Gregorin and Ditchfield, 2005, p. 404). Similar interpretations are found in more philosophical (e.g. Richter, 2005) and mathematical (Miyakawa and Narushima, 2004) literature (see Table 1).

In what follows we give a few simple examples that demonstrate that (1) use of ACCTRAN does not systematically lead to preference for reversals over parallelism—in just as many cases DELTRAN does so; (2) using either globally for a character with a complex history can lead to inconsistent optimizations (e.g. favour loss of a complex character in one part of the tree, but parallelism in another); and (3) in some

cases involving missing data or inapplicable data, neither ACCTRAN nor DELTRAN are appropriate (at least as implemented in most popular software) because they can lead to optimizations contradicted by the evidence.

Examples

In the examples that follow, we present a simple binary character under Fitch parsimony (equal transformation costs) with the states absent (0) and present (1). The character could be any complex trait; arbitrarily for our examples let it be a “complex” light sensory organ (LSO) on insect antennae. Let us first look at an example of what De Pinna (1991) had in mind. In Fig. 1A the LSO is present in taxa A and C, but absent in all others. Because B is more closely related to A than is C, parsimony requires two steps to explain the data—either parallel gains, or one gain and a secondary loss of the LSO. ACCTRAN optimization, by favouring change as close as possible to the root, supports a single gain of LSO with a secondary loss in B. DELTRAN, however, supports parallel gains of LSO, which is in clear conflict with the stronger original conjecture of homology. Is ACCTRAN therefore better? The answer is no, as can be seen when the distribution of LSO

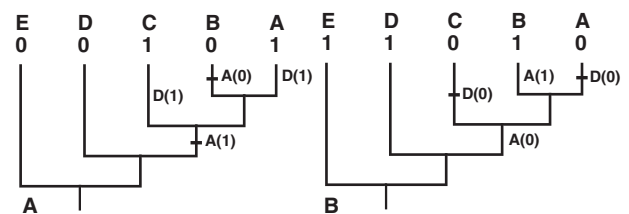

Fig. 1. A simple example showing ambiguous optimization where in A, De Pinna’s (1991) logic holds and in B, it does not. Rows above the tree show taxon names and states for LSO. Alternative optimizations are indicated with A (ACCTRAN) and D (DELTRAN) followed by the character state in parentheses. Dashes indicate the preferred optimization. LSO is present in A and C, and ACCTRAN preserves homology of this complex structure by favouring early gain and secondary loss, while DELTRAN favours parallel gains. In B, however, the distribution of character states has been inverted so that absence is the locally derived state: here DELTRAN preserves homology of LSO, while ACCTRAN suggests a novel origin in taxon B.

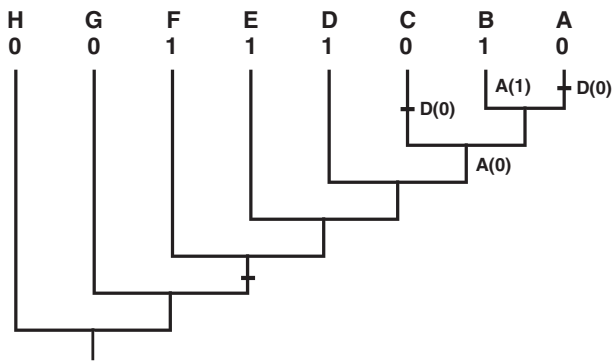

Fig. 2. An example showing absence as the globally primitive but locally derived state. Rows above the tree show taxon names and states for LSO. Alternative optimizations are indicated with A (ACCTRAN) and D (DELTRAN) followed by the character state in parentheses. Dashes indicate the preferred optimization. Here LSO is primitively absent, but its origin is unambiguously optimized to the clade A–F. Distally, however, its optimization is ambiguous and DELTRAN is necessary to preserve homology of LSO in all taxa where it occurs.

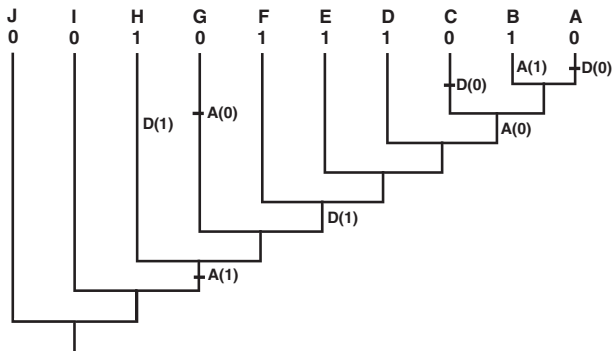

Fig. 3. Example showing that global use of a single algorithm may lead to inconsistent optimizations. Rows above the tree show taxon names and states for LSO. Alternative optimizations are indicated with A (ACCTRAN) and D (DELTRAN) followed by the character state in parentheses. Dashes indicate the preferred optimization. In this case ACCTRAN favours a single origin of LSO basally, but DELTRAN preserves homology of LSO distally by favouring parallel losses. Under this combined approach LSO evolves once and is lost three times, while using ACCTRAN globally would favour a parallel gain of LSO in the distal part of the cladogram.

among taxa is inverted. Now that LSO is primitively present (Fig. 1B).

This example clearly shows that the *primitive* state is key. Is ACCTRAN then better whenever the primitive state is absence? Again the answer is no. Figure 2 shows an example where the LSO is primitively absent; however, ambiguity occurs within the “LSO clade”, where the LSO has either been lost in parallel (DELTRAN) or been lost once and regained (ACCTRAN). Here again DELTRAN preserves homology better.

This example shows that we must examine which states are primitive or derived both *globally*, i.e. at the

root of the tree, and *locally*, i.e. at the node(s) where the character state optimization is ambiguous. This consideration leads us to our next point, when character history is complicated global character optimization under a single algorithm may give different results in different locations on the tree. In Fig. 3 the character LSO requires four steps. LSO is primitively absent, but basally ACCTRAN optimization preserves homology by favouring a single origin, with a secondary loss in G. Distally, however, ACCTRAN would favour a single loss and the second origin of LSO. Here a combination of ACCTRAN (basally) and DELTRAN (distally) best preserves the stronger conjecture of homology. In other words, instead of “blind” global application of one method it is necessary to examine and optimize each ambiguity in isolation.

Finally, as pointed out by Farris (1970), uncritical use of ACCTRAN may result in spurious resolution when there is missing data or inapplicable entries. In such

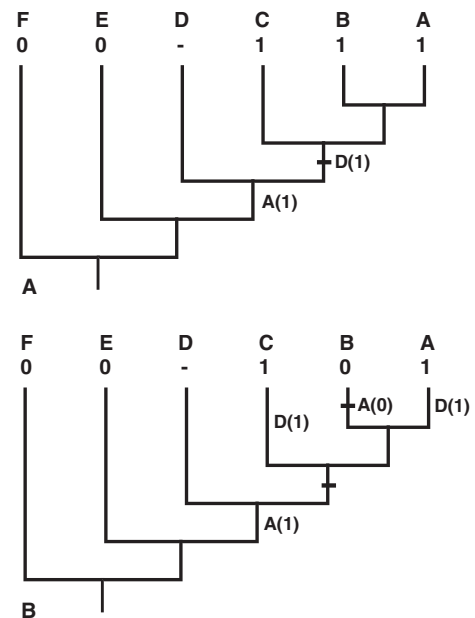

Fig. 4. Example showing that in the case of missing data or inapplicables ACCTRAN may lead to spurious results, and in some cases neither ACCTRAN nor DELTRAN finds the best optimization. Rows above the tree show taxon names and states for LSO. Alternative optimizations are indicated with A (ACCTRAN) and D (DELTRAN) followed by the character state in parentheses. Dashes indicate the preferred optimization. In A, taxon A lacks antennae so the LSO is inapplicable for D. Under ACCTRAN, this optimizes the character to the clade A–D, uniting D with A–C based on the presence of LSO on an absent antennae. Here DELTRAN is necessary. In B, taxon D still lacks antennae, but in taxon B the LSO is absent. In this case, ACCTRAN suffers from the same problem as in A, but DELTRAN suggests parallel origins of the LSO. Neither ACCTRAN nor DELTRAN preserve the homology of the LSO in a manner consistent with the evidence, so an alternative optimization should be used.

cases neither ACCTRAN nor DELTRAN may achieve the “best” optimization (Fig. 4).

It is not surprising considering the discussion above that real data sets contain a mosaic of losses, gains, and inapplicables, and that the simplistic application of a single method will fail. For example, Miller and Hormiga (2004) and Agnarsson (2004, 2006) found ACCTRAN and DELTRAN each did a better job of preserving homology of complex character states (or avoiding parallelism) in approximately 50% of the cases. Additionally, some characters lacked asymmetry in character state complexity, and were optimized based on other criteria or left ambiguous.

Kitching et al. (1998, p. 205) suggest that “Delayed transformation accounts for *homoplasy* in terms of independent gains.” As the above examples clarify, this definition is at best imprecise. More accurately, DELTRAN explains homoplasy in terms of parallel gains of the *locally* derived state, whether presence or absence, red or blue, etc. Similarly, ACCTRAN explains homoplasy in terms of a gain in the *locally* derived state and a reversal to the *locally* primitive state.

Beyond Fitch optimization

As cautioned by Swofford and Maddison (1992, p. 220): “character state reconstructions can provide a powerful mechanism for studying many facets of the evolutionary process. However, the zeal with which these techniques are sometimes advocated belies the complexity of the problem.” Hence, if we were to prefer parallel losses of complex characters when optimization is ambiguous, how should we interpret “unambiguous” optimizations (under parsimony) that imply parallel evolution of complex traits? Is there not more to homology than congruence (e.g. Kearney and Rieppel, 2006)? Typical practice in (Fitch) parsimony character reconstruction has symmetrical cost of change between character states (Omland, 1999). However, asymmetrical transformation costs could be used (Goloboff, 1997; Maddison, 1994; Sankoff and Rousseau, 1975), and asymmetric rates of change between character states is a major topic in the literature on likelihood and Bayesian optimization (e.g. Cunningham et al., 1998; Cunningham, 1999; Mooers and Schluter, 1999; Ree and Donoghue, 1999; Schultz and Churchill, 1999; Oakley and Cunningham, 2002). Of course, establishing appropriate parameters for asymmetric character state change is not a small problem. For example, Oakley and Cunningham (2002) presented a tree that required one of two “unlikely evolutionary histories” (p. 1426): either compound eyes similar in detail to those of other arthropods evolved independently in ostracods, or they have been lost “in a seemingly inordinate number of arthropod lineages” (p. 1426). In their exploration of asymmetric character state

change parameters, they found that significant support for a single-origin/multiple-loss hypothesis required a skew > 30:1. But as the authors point out, it is difficult to know whether this is an unrealistic parameter: “perhaps eyes really are lost over 30 times as often as gained during evolution” (p. 1429). A recent phylogeny of stick insects implies a similar pair of unlikely alternative evolutionary histories: either wings have re-evolved from wingless ancestors several times or wings have been independently lost many times (Whiting et al., 2003; Trueman et al., 2004; Whiting and Whiting, 2004). One might reasonably argue that secondary loss of wings is more likely (or “simpler”) than their novel origin, but selecting appropriate values for asymmetric rates of character state change remains problematic.

We believe that asymmetry in character state complexity is important information for understanding character evolution. Character state complexity can be used to favour preserving the stronger statement of homology when Fitch optimization is ambiguous. More broadly, it can be used to explore less than Fitch-parsimonious scenarios of character evolution that preserve homology of complex character states.

Acknowledgments

We thank J. Coddington, M. Kuntner, K. Pickett, P. Goloboff and an anonymous reviewer for helpful comments on a draft of this paper. This work was supported in part by a Killam Postdoctoral Fellowship, and a Slovenian Research Agency research fellowship (ARRS Z1-9799-0618-07) to I.A. and a Schlinger Foundation postdoctoral fellowship (California Academy of Sciences) to J.M.

References

- Agnarsson, I., 2004. Morphological phylogeny of cobweb spiders and their relatives (Araneae, Araneoidea, Theridiidae). *Zool. J. Linn. Soc.* 141, 447–626.
- Agnarsson, I., 2006. A revision of the New World *eximius* lineage of *Anelosimus* (Araneae, Theridiidae) and a phylogenetic analysis using worldwide exemplars. *Zool. J. Linn. Soc.* 146, 453–593.
- Agnarsson, I., Coddington, J.A., 2008. Quantitative tests of primary homology. *Cladistics* 24, 51–61.
- Agnarsson, I., Coddington, J.A., Knoflach, B., 2007. Morphology and evolution of cobweb spider male genitalia (Araneae: Theridiidae). *J. Arachnol.* 35, 334–395.
- Benjamin, S.P., 2004. Taxonomic revision and phylogenetic hypothesis for the jumping spider subfamily Ballinae (Araneae, Salticidae). *Zool. J. Linn. Soc.* 142, 1–82.
- Britto, M.R., 2003. Phylogeny of the subfamily Corydoradinae Hoedeman, 1952 (Siluriformes: Callichthyidae), with a definition of its genera. *Proc. Acad. Nat. Sci. Philadelphia* 153, 119–154.
- Cunningham, C.W., 1999. Some limitations of ancestral character-state reconstructions when testing evolutionary hypotheses. *Syst. Biol.* 48, 665–674.

- Cunningham, C.W., Omland, K.E., Oakley, T.H., 1998. Reconstructing ancestral character states: a critical reappraisal. *Trends Ecol. Evol.* 13, 361–366.
- De Pinna, M.C.C., 1991. Concepts and tests of homology in the cladistic paradigm. *Cladistics* 7, 367–394.
- Farris, J.S., 1970. Methods for computing Wagner trees. *Syst. Zool.* 19, 83–92.
- Forest, L., Savolainen, V., Chase, M.W., Lupia, R., Bruneau, A., Cranes, P.R., 2005. Teasing apart molecular- versus fossil-based error estimates when dating phylogenetic trees: a case study in the birch family (Betulaceae). *Syst. Bot.* 30, 118–133.
- Gaubert, P., Wozencraft, W.C., Cordeiro-Estrela, P., Veron, G., 2005. Mosaics of convergences and noise in morphological phylogenies: what's in a viverrid-like carnivoran? *Syst. Biol.* 54, 865–894.
- Goloboff, P., 1997. Self-weighted optimization: tree searches and character state reconstructions under implied transformation costs. *Cladistics* 13, 225–246.
- Gregorin, R., Ditchfield, A.D., 2005. New genus and species of nectar-feeding bat in the tribe Lonchophyllini (Phyllostomidae: Glossophaginae) from northeastern Brazil. *J. Mammal.* 86, 403–414.
- Griswold, C.E., Coddington, J.A., Hormiga, G., Scharff, N., 1998. Phylogeny of the orb-web building spiders (Araneae, Orbicularia: Deinopoidea, Araneoidea). *Zool. J. Linn. Soc.* 123, 1–99.
- Hilton, E.J., 2003. Comparative osteology and phylogenetic systematics of fossil and living bony-tongue fishes (Actinopterygii, Teleostei, Osteoglossomorpha). *Zool. J. Linn. Soc.* 137, 1–100.
- Hormiga, G., 1994. Cladistics and the comparative morphology of linyphiid spiders and their relatives (Araneae, Aranoidea, Linyphiidae). *Zool. J. Linn. Soc.* 111, 1–71.
- Hormiga, G., 2003. *Weintrauboa*, a new genus of pimoid spiders from Japan and adjacent islands, with comments on the monophyly and diagnosis of the family Pimoidae and the genus *Pimoida* (Araneae, Araneae). *Zool. J. Linn. Soc.* 139, 261–281.
- Kearney, M., Rieppel, O., 2006. Rejecting “the given” in systematics. *Cladistics* 22, 369–377.
- Kitching, R.L., Forey, P.L., Humphries, C.J., Williams, D.M., 1998. *Cladistics: The Theory and Practice of Parsimony Analysis*, 2nd edn. Oxford University Press, Oxford.
- Maddison, D.R., 1994. Phylogenetic methods for inferring the evolutionary history and processes of change in discretely valued characters. *Annu. Rev. Ecol. Syst.* 39, 267–292.
- Maddison, D.R., Maddison, W.P., 2001. *MacClade 4.04: Analysis of phylogeny and character evolution*. Sinauer Associates, Sunderland, MA.
- Maddison, W.P., Maddison, D.R., 1992. *MacClade version 3: Analysis of phylogeny and character evolution*. Sinauer Associates, Sunderland, MA.
- Maddison, W.P., Maddison, D.R., 2002. *MacClade: Analysis of Phylogeny and Character Evolution, Version 4.01*. Sinauer Associates, Sunderland, MA.
- Martel, E., Poncet, V., Lamy, F., Siljak-Yakovlev, S., Lejeune, B., Sarr, A., 2004. Chromosome evolution of *Pennisetum* species (Poaceae): implications of ITS phylogeny. *Plant. Syst. Evol.* 249, 139–149.
- Miller, J.A., Hormiga, G., 2004. Clade stability and the addition of data: a case study from erigonine spiders (Araneae: Linyphiidae, Erigoninae). *Cladistics* 20, 385–442.
- Minaka, N., 1993. Algebraic properties of the most parsimonious reconstructions of the hypothetical ancestors on a given tree. *Forma* 8, 277–296.
- Miyakawa, K., Narushima, H., 2004. Lattice-theoretic properties of MPR-posets in phylogeny. *Discrete Appl. Math.* 134, 169–192.
- Mooers, A.Ø., Schluter, D., 1999. Reconstructing ancestor states with maximum likelihood: support for one- and two-rate models. *Syst. Biol.* 48, 623–633.
- Mooring, M.S., Blumstein, D.T., Stoner, C.J., 2004. The evolution of parasite-defence grooming in ungulates. *Biol. J. Linn. Soc.* 81, 17–37.
- Narushima, H., Misheva, N., 2002. On characteristics of ancestral character-state reconstructions under the accelerated transformation optimization. *Discrete Appl. Math.* 122, 195–209.
- Nelson, G.J., Platnick, N.I., 1981. *Systematics and Biogeography: Cladistics and Vicariance*. Columbia University Press, New York.
- Oakley, T.H., Cunningham, C.W., 2002. Molecular phylogenetic evidence for the independent evolutionary origin of an arthropod compound eye. *Proc. Natl Acad. Sci. USA* 99, 1426–1430.
- Omland, K.E., 1999. The assumptions and challenges of ancestral state reconstructions. *Syst. Biol.* 48, 604–611.
- Patterson, C., 1982. Morphological characters and homology. In: Joysey, K.A., Friday, A.E. (Eds.), *Problems of Phylogenetic Reconstruction*, Academic Press, London, pp. 21–74.
- Prendini, L., Weygoldt, P., Wheeler, W.C., 2005. Systematics of the *Damon variegatus* group of African whip spiders (Chelicerata: Amblypygi): evidence from behaviour, morphology and DNA. *Org. Divers. Evol.* 5, 203–236.
- Ree, R.H., Donoghue, M.J., 1999. Inferring rates of change in flower symmetry in asterid angiosperms. *Syst. Biol.* 48, 633–641.
- Richter, S., 2005. Homologies in phylogenetic analyses - concept and tests. *Theory Biosci.* 124, 105–120.
- Rieppel, O., Kearney, M., 2002. Similarity. *Biol. J. Linn. Soc.* 75, 59–82.
- Sankoff, D., Rousseau, P., 1975. Locating the vertices of a Steiner tree in an arbitrary space. *Math. Program.* 9, 240–246.
- Scholtz, G., 2005. Homology and ontogeny: pattern and process in comparative developmental biology. *Theory Biosci.* 124, 121–143.
- Schuh, R.T., 2000. *Biological Systematics: Principles and Applications*. Cornell University Press, Ithaca, NY.
- Schultz, T.R., Churchill, G.A., 1999. The role of subjectivity in reconstructing ancestral character states: a Bayesian approach to unknown rates, states, and transformation asymmetries. *Syst. Biol.* 48, 651–664.
- Shelley, E.L., Blumstein, D.T., 2005. The evolution of vocal alarm communication in rodents. *Behav. Ecol.* 16, 169–177.
- Swofford, D.L., Maddison, W.P., 1987. Reconstructing ancestral character states under Wagner parsimony. *Math. Biosci.* 87, 199–229.
- Swofford, D.L., Maddison, W.P., 1992. Parsimony, character-state reconstructions, and evolutionary inferences. In: Mayden, R.L., (Ed.), *Systematics, Historical Ecology, and North American Freshwater Fishes*. Stanford University Press, Stanford, CA, pp. 187–223.
- Trueman, J.W.H., Pfeil, B.E., Kelchner, S.A., Yeates, D.K., 2004. Did stick insects really regain their wings? *Syst. Entomol.* 29, 138–139.
- Whiting, M.F., Whiting, A.S., 2004. Is wing recurrence really impossible?: a reply to Trueman et al. *Syst. Entomol.* 29, 140–141.
- Whiting, M.F., Bradler, S., Maxwell, T., 2003. Loss and recovery of wings in stick insects. *Nature* 421, 264–267.
- Wiens, J.J., 2001. Character analysis in morphological phylogenetics: problems and solutions. *Syst. Biol.* 50, 689–699.
- Zanata, A.M., Vari, R.P., 2005. The family Alestidae (Ostariophysi, Characiformes): a phylogenetic analysis of a trans-Atlantic clade. *Zool. J. Linn. Soc.* 145, 1–144.